

ENV 501 / GR A3 30

Exercise session 3:

Handwritten MFA + Jupyter Notebook MFA

Teaching assistant:

Jair Campfens jair.campfens@epfl.ch

Leonard Lechot: leonard.lechot@epfl.ch

Exercise — Photovoltaic cell production

The production of photovoltaic cells can be represented in a simplified manner depicting only the two main processes; silicon wafer production and photocell production. The flow data for each of the processes are as follows:

Wafer production (for 1kg silicon wafers)	
Input	
Silicon [kg]	1
Energy [MJ]	420
Output	
Silicon wafers [kg]	1

Photocell production (for 1m ² photovoltaic cells)	
Input	
Energy [MJ]	13.6
Glass [kg]	10
Silicon wafers [kg]	1.6
Output	
Photovoltaic cells [m ²]	1

1. Perform a system analysis: establish the system diagram and derive the balance equations.
2. Develop the output equations considering each of the inputs, and calculate the amount of energy, silicon and glass needed to produce 1 m² of PV cells.

Exercise — Photovoltaic cell production

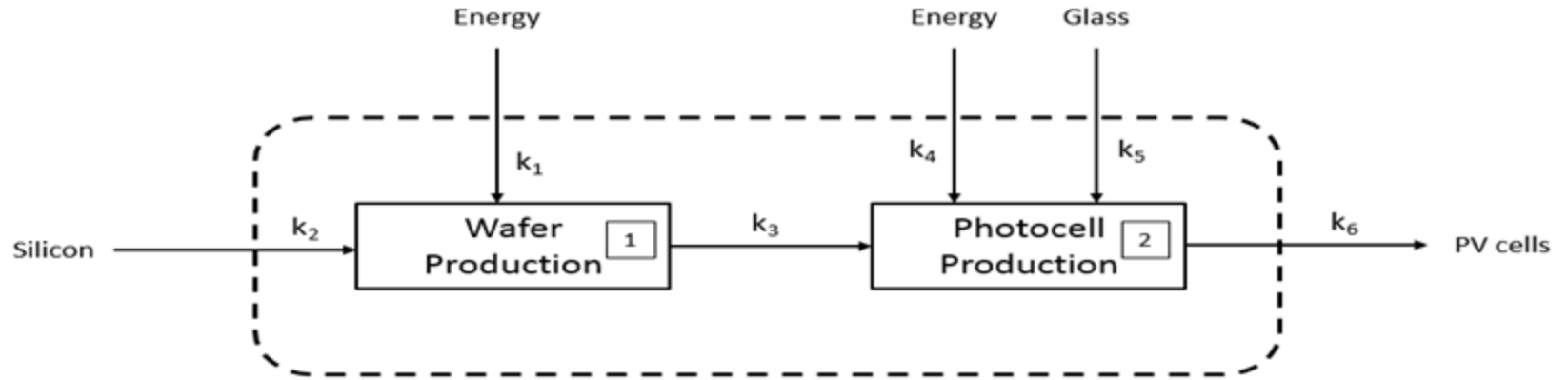

Exercise — Photovoltaic cell production

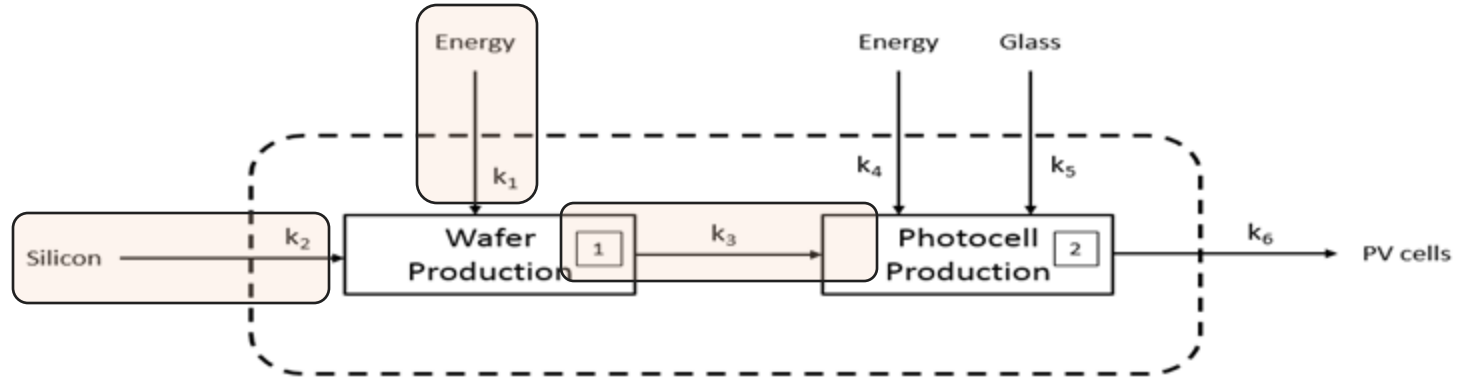

$$\text{Input}_{E1} \cdot k_1 + \text{Input}_{Si} \cdot k_2 = \text{Output}_1 \cdot k_3$$

Exercise — Photovoltaic cell production

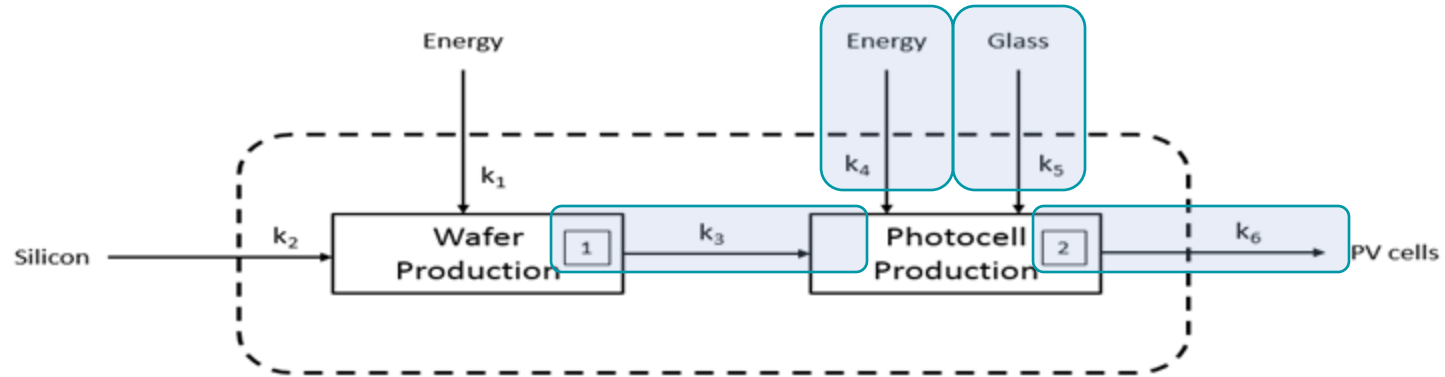

$$\text{Input}_{E1} \cdot k_1 + \text{Input}_{Si} \cdot k_2 = \text{Output}_1 \cdot k_3$$

$$\text{Output}_1 \cdot k_3 + \text{Input}_{E2} \cdot k_4 + \text{Input}_G \cdot k_5 = \text{Output}_2 \cdot k_6$$

Exercise — Photovoltaic cell production

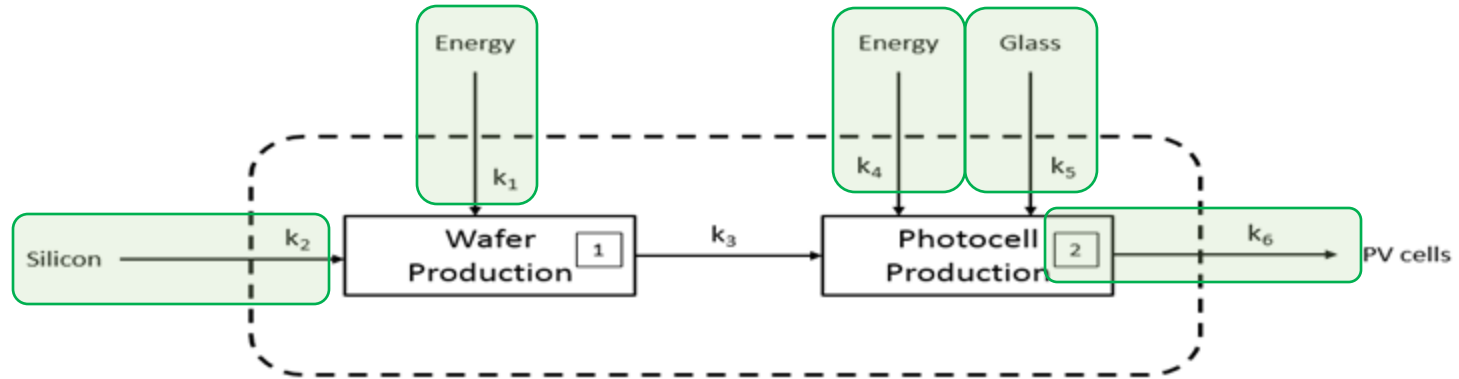

$$\text{Input}_{E1} \cdot k_1 + \text{Input}_{Si} \cdot k_2 = \text{Output}_1 \cdot k_3$$

$$\text{Output}_1 \cdot k_3 + \text{Input}_{E2} \cdot k_4 + \text{Input}_G \cdot k_5 = \text{Output}_2 \cdot k_6$$

$$\text{Input}_{E1} \cdot k_1 + \text{Input}_{Si} \cdot k_2 + \text{Input}_{E2} \cdot k_4 + \text{Input}_G \cdot k_5 = \text{Output}_2 \cdot k_6$$

Exercise — Photovoltaic cell production

The production of photovoltaic cells can be represented in a simplified manner depicting only the two main processes; silicon wafer production and photocell production. The flow data for each of the processes are as follows:

Wafer production (for 1kg silicon wafers)	
Input	
Silicon [kg]	1
Energy [MJ]	420
Output	
Silicon wafers [kg]	1

Photocell production (for 1m ² photovoltaic cells)	
Input	
Energy [MJ]	13.6
Glass [kg]	10
Silicon wafers [kg]	1.6
Output	
Photovoltaic cells [m ²]	1

1. Perform a system analysis: establish the system diagram and derive the balance equations.
2. Develop the output equations considering each of the inputs, and calculate the amount of energy, silicon and glass needed to produce 1 m² of PV cells.

Exercise — Photovoltaic cell production

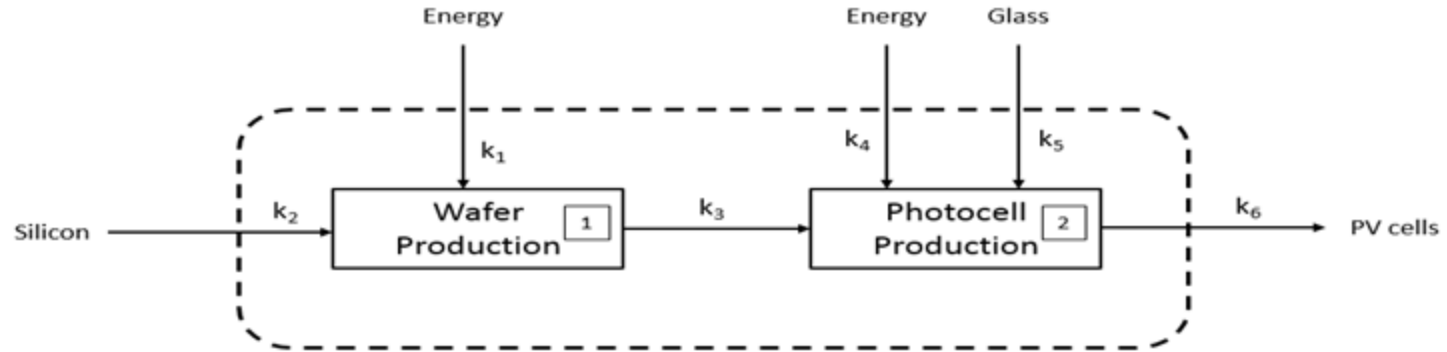

$$x \text{ kg Si-wafers} = k_2 \cdot x \text{ kg Si} + k_1 \cdot x \text{ MJ energy}$$

$$\mathbf{x \text{ kg Si-wafers} = 1 \cdot x \text{ kg Si} + 420 \cdot x \text{ MJ energy}}$$

$$y \text{ m}^2 \text{ PV cells} = k_3 \cdot y \text{ Si-wafers} + k_5 \cdot y \text{ kg glass} + k_4 \cdot y \text{ MJ energy}$$

$$\mathbf{y \text{ m}^2 \text{ PV cells} = 1.6 \cdot y \text{ Si-wafers} + 10 \cdot y \text{ kg glass} + 13.6 \cdot y \text{ MJ energy}}$$

Exercise — Photovoltaic cell production

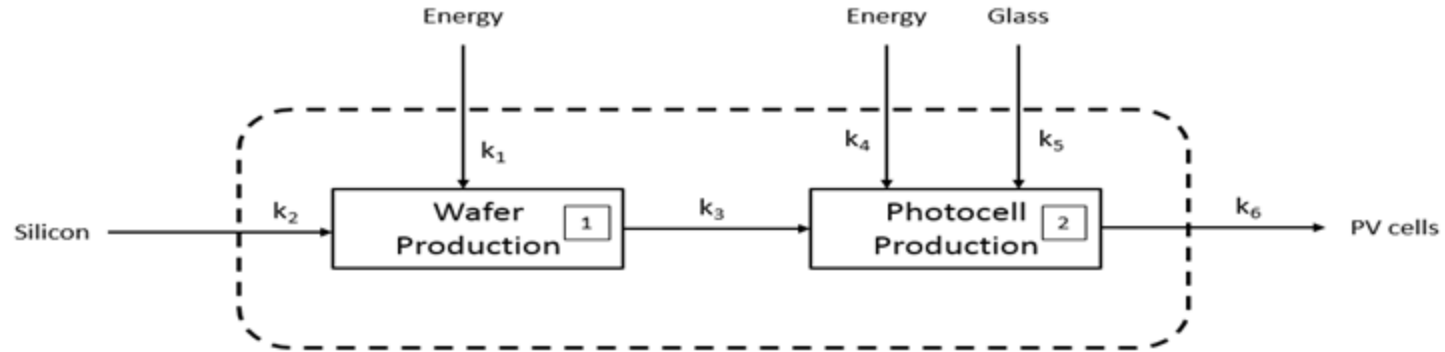

Therefore, to produce 1 m² of PV cells, we need 1.6·1 kg Si, 10·1 kg glass, and (420·1.6 + 13.6·1) MJ energy.

→ **1.6 kg Si, 10 kg glass, and 685.6 MJ** energy is required.